

Innotech Solutions

Technological Market Products SL



LED Solar Street Light: LD-STB



Code	LD-STB40W	LD-STB48W	LD-STE60W	LD-STE80W
Input voltage	3.2V	3.2V	3.2V	3.2V
Power	40w	48w	60w	80w
Light Size	660*290*156mm	720*270.5*175.7mm	660*290*156mm	720*270.5*175.7mm
Net weight	11.3kg	12.1kg	11.3kg	16.2kg
Lumens	3200lm	3800lm	5400lm	7000lm
Efficacy	80lm/w	80lm/w	90lm/w	88lm/w
Material	Die Casting Aluminum			
Led chip	Cree SMD3030			
CRI	>80			
CCT	2700-6500K			
Beam Angle	140*70°			
Solar Panel info	5V 65W Solar panel SIZE: 670*603*30mm	5V 75W Solar panel SIZE: 836*516*30mm	5V 95W Solar panel SIZE: 836*603*30mm	5V 150W Solar panel SIZE: 992*836*30mm
Battery	3.2V/50AH Lithium Iron Phosphate Battery- LiFePO ₄	3.2V/60AH Lithium Iron Phosphate Battery- LiFePO ₄	3.2V/65AH Lithium Iron Phosphate Battery- LiFePO ₄	3.2V/140AH Lithium Iron Phosphate Battery- LiFePO ₄
Surge Protection	4KV			
Lighting Mode	All night lighting, the first 4 hrs full power lighting, the rest night lighting is intelligent power control.			
Control Mode	Light sensor, intelligent control			
Install suggestion	6-8m Height 25-35m Distance	7-9m Height 30-40m Distance	6-9m Height 35-45m Distance	8-10m Height 35-50m Distance
Operating temperature	-47~70°C			

LED Solar Street Light: LD-STE



Code	LD-STE20WA	LD-STE20WB	LD-STE40W	LD-STE60W
Input voltage	3.2V	3.2V	3.2V	3.2V
Power	20w	20w	40w	60w
Light Size	497*209*55mm	497*209*55mm	578*252*80mm	650*206*63mm
Net weight	7.8kg	7.8kg	8.4kg	9.2kg
Lumens	1800lm	1800lm	3200lm	5400lm
Efficacy	90lm/w	90lm/w	80lm/w	90lm/w
Material	Die Casting Aluminum			
Led chip	Cree SMD2835			
CRI	>80			
CCT	2700-6500K			
Beam Angle	140*70°			
Solar Panel info	5V 30W Solar panel SIZE: 361*470*30mm	5V 45W Solar panel SIZE: 556*516*30mm	5V 65W Solar panel SIZE: 670*603*30mm	5V 95W Solar panel SIZE: 836*603*30mm
Battery	3.2V/20AH Lithium Iron Phosphate Battery- LiFePO ₄	3.2V/35AH Lithium Iron Phosphate Battery- LiFePO ₄	3.2V/50AH Lithium Iron Phosphate Battery- LiFePO ₄	3.2V/65AH Lithium Iron Phosphate Battery- LiFePO ₄
Surge Protection	4KV			
Lighting Mode	All night lighting, the first 4 hrs full power lighting, the rest night lighting is intelligent power control.			
Control Mode	Light sensor, intelligent control			
Install suggestion	5-6m Height 20-30m Distance	5-6m Height 20-30m Distance	6-8m Height 25-35m Distance	8-10m Height 35-45m Distance
Operating temperature	-47~70°C			

LED Solar Street Light: LD-STL

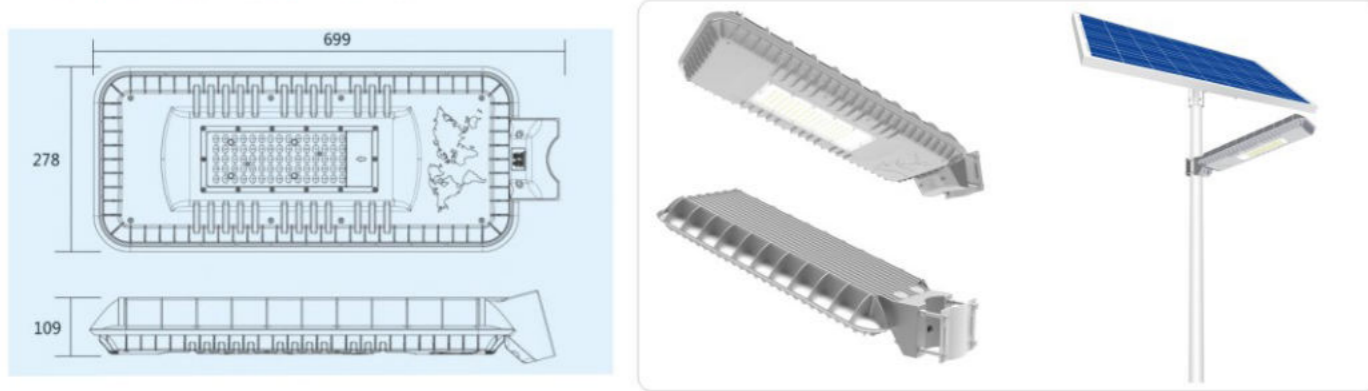

Code	LD-STL60W	LD-STL100W	LD-STL150W
Input voltage	3.2V	3.2V	3.2V
Power	60w	100w	150w
Light Size	699*278*109mm	699*278*109mm	699*278*109mm
Net weight	14.5kg	18.8kg	18.9kg
Lumens	5400lm	8000lm	13600lm
Efficacy	90lm/w	80lm/w	90lm/w
Material	Die Casting Aluminum		
Led chip	Cree SMD3030		
CRI	>80		
CCT	2700-6500K		
Beam Angle	140°70°		
Solar Panel info	5V 95W Solar panel size: 836*603*30mm	5V 150W Solar panel size: 992*836*30mm	5V 190W Solar panel size: 836*670*30mm*2pcs
Battery	3.2V/65AH Lithium Iron Phosphate Battery- LiFePO ₄	3.2V/160AH Lithium Iron Phosphate Battery- LiFePO ₄	3.2V/200AH Lithium Iron Phosphate Battery- LiFePO ₄
Surge Protection	4KV		
Lighting Mode	All night lighting, the first 4 hrs full power lighting, the rest night lighting is intelligent power control.		
Control Mode	Light sensor, intelligent control		
Install suggestion	7-8m Height 35-45m Distance	8-10m Height 40-50m Distance	10-12m Height 40-50m Distance
Operating temperature	-47~70°C		

LED Solar Street Light: LD-STY

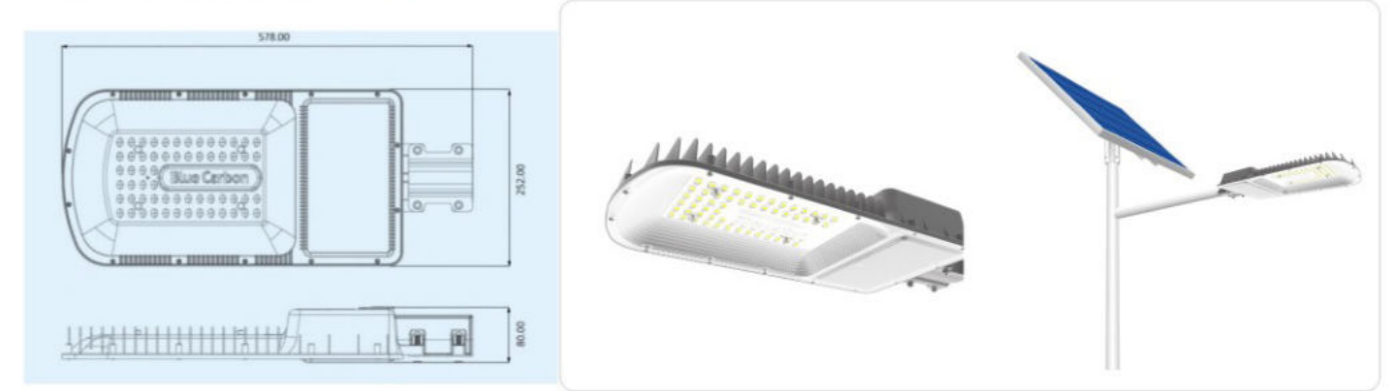

Code	LD-STY40W	LD-STY60W
Input voltage	3.2V	3.2V
Power	40w	60w
Light Size	578*252*80mm	578*252*80mm
Net weight	8.6kg	11.3kg
Lumens	3200lm	5400lm
Efficacy	80lm/w	90lm/w
Material	Die Casting Aluminum	
Led chip	Cree SMD3030	
CRI	>80	
CCT	2700-6500K	
Beam Angle	140°70°	
Solar Panel info	5V 65W Solar panel SIZE: 670*603*30mm	5V 95W Solar panel SIZE: 836*670*30mm
Battery	3.2V/50AH Lithium Iron Phosphate Battery- LiFePO ₄	3.2V/65AH Lithium Iron Phosphate Battery- LiFePO ₄
Surge Protection	4KV	
Lighting Mode	All night lighting, the first 4 hrs full power lighting, the rest night lighting is intelligent power control.	
Control Mode	Light sensor, intelligent control	
Install suggestion	6-8m Height 25-35m Distance	8-10m Height 35-45m Distance
Operating temperature	-47~70°C	

• Led Solar Street Light: LD-SPB-7W

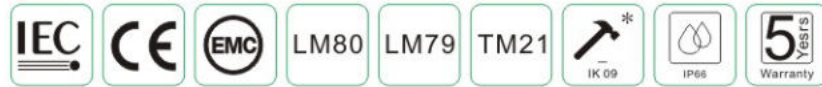
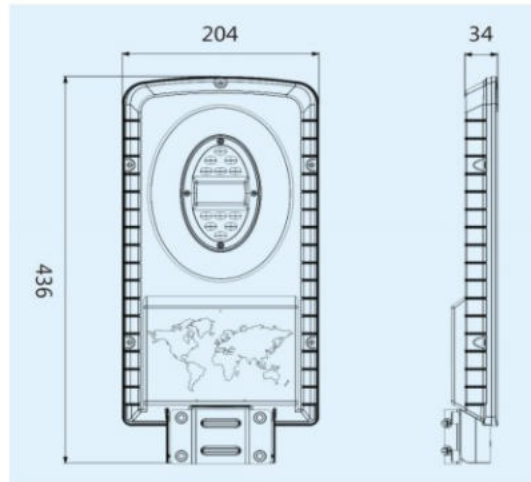

Code	LD-SPB-7W
Input voltage	3.2V
Power	7w
Light Size	436*204*34mm
Net weight	2.1kg
Lumens	450lm
Efficacy	70lm/w
Material	Die Casting Aluminum
Led chip	Cree SMD2835
CRI	>80
CCT	2700-6500K
Beam Angle	140*70°
Solar Panel info	5V 15W Solar panel SIZE: 416*184*30mm
Battery	3.2V/13AH Lithium Iron Phosphate Battery- LiFePO4
Surge Protection	4KV
Lighting Mode	All night lighting, the first 4 hrs full power lighting, the rest night lighting is intelligent power control.
Control Mode	Light sensor, intelligent control
Install suggestion	3-4m Height 10-15m Distance
Operating temperature	-47-70°C

• Solar Flood Light: SWSF02

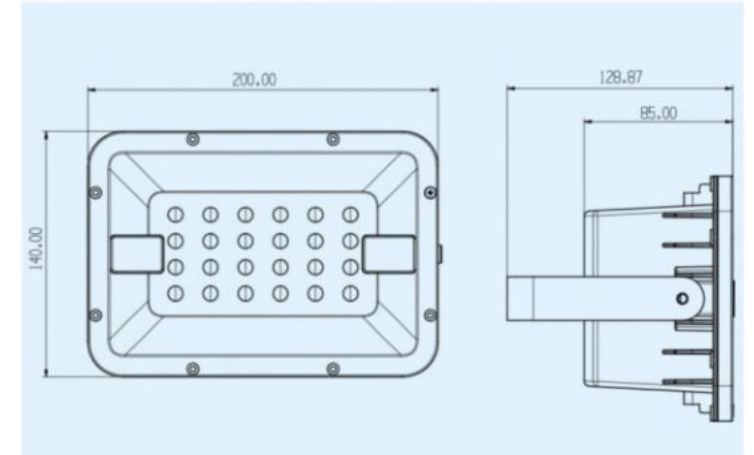

Code	SWSF02
Power	10W
Light Size	200*140*128mm
Net weight	3.9KG
Lumens	810lm
Efficacy	80lm/w
Material	Die Casting Aluminum
CRI	>70
CCT	2700-6500K
Beam Angle	120°
Solar Panel info	Panel Power:36W, Size:583*360mm, Lifetime:25 years
Battery	3.2V/20000mAh 95%DOD LiFePo4 Battery Life span:8-12years
Lighting Mode	Full power lighting for the first 4 hours, intelligent power control after 4 hours
	remote control
Application	streets , roads, parks, squares , gardens and other public places

· Solar Flood Light: SWSF02

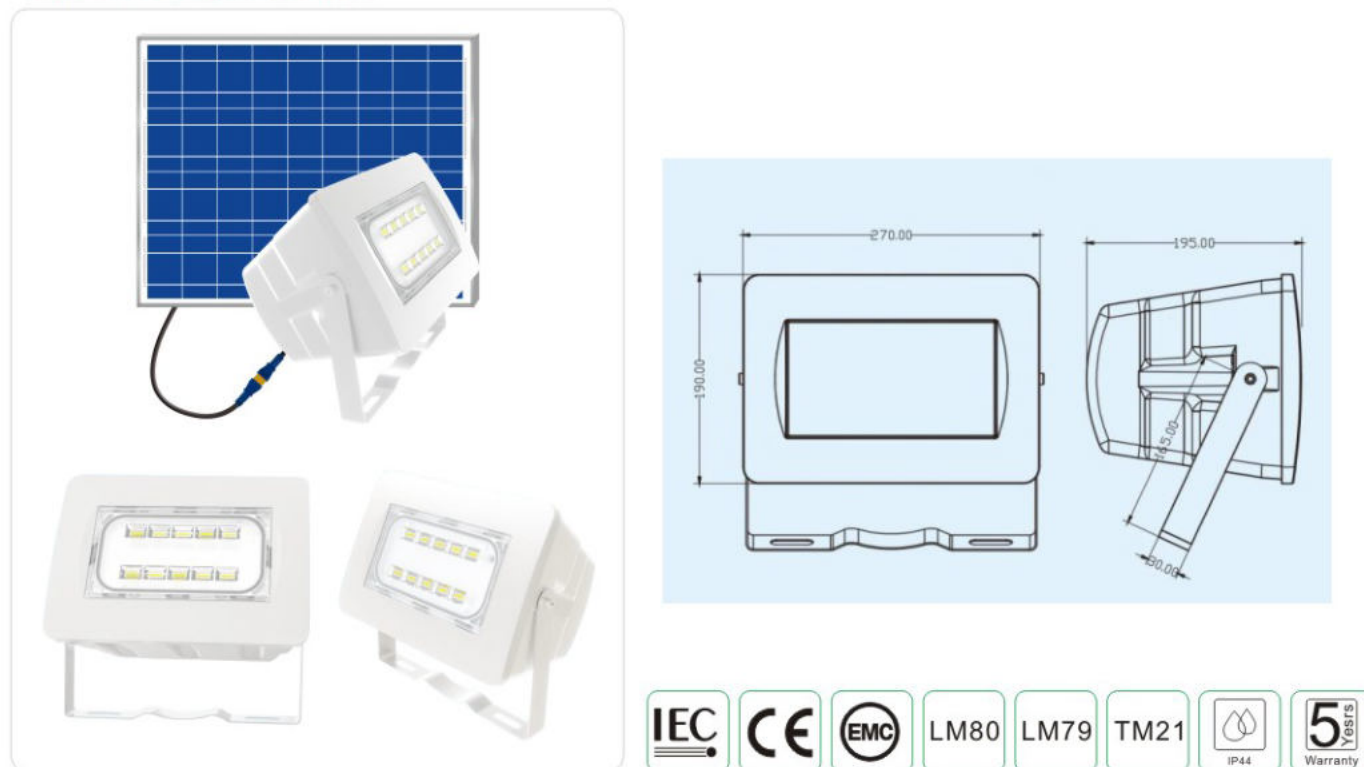

Code	SWSF02
Power	60W
Light Size	190*270*195mm
Net weight	9.6kg
Lumens	4500lm
Efficacy	80lm/w
Material	Die Casting Aluminum
CRI	>70
CCT	2700-6500K
Beam Angle	120°
Solar Panel info	Power:65W, Size:670*603mm Lifetime:25 years
Battery	3.2V/50000mAH 95%DOD LiFePo4Battery Life span:8-12years
Lighting Mode	Full power lighting for the first 4 hours, intelligent power control after 4 hours
Control Mode	remote control
Application	streets , roads, parks, squares , gardens and other public places

· Solar Flood Light: SWSF02

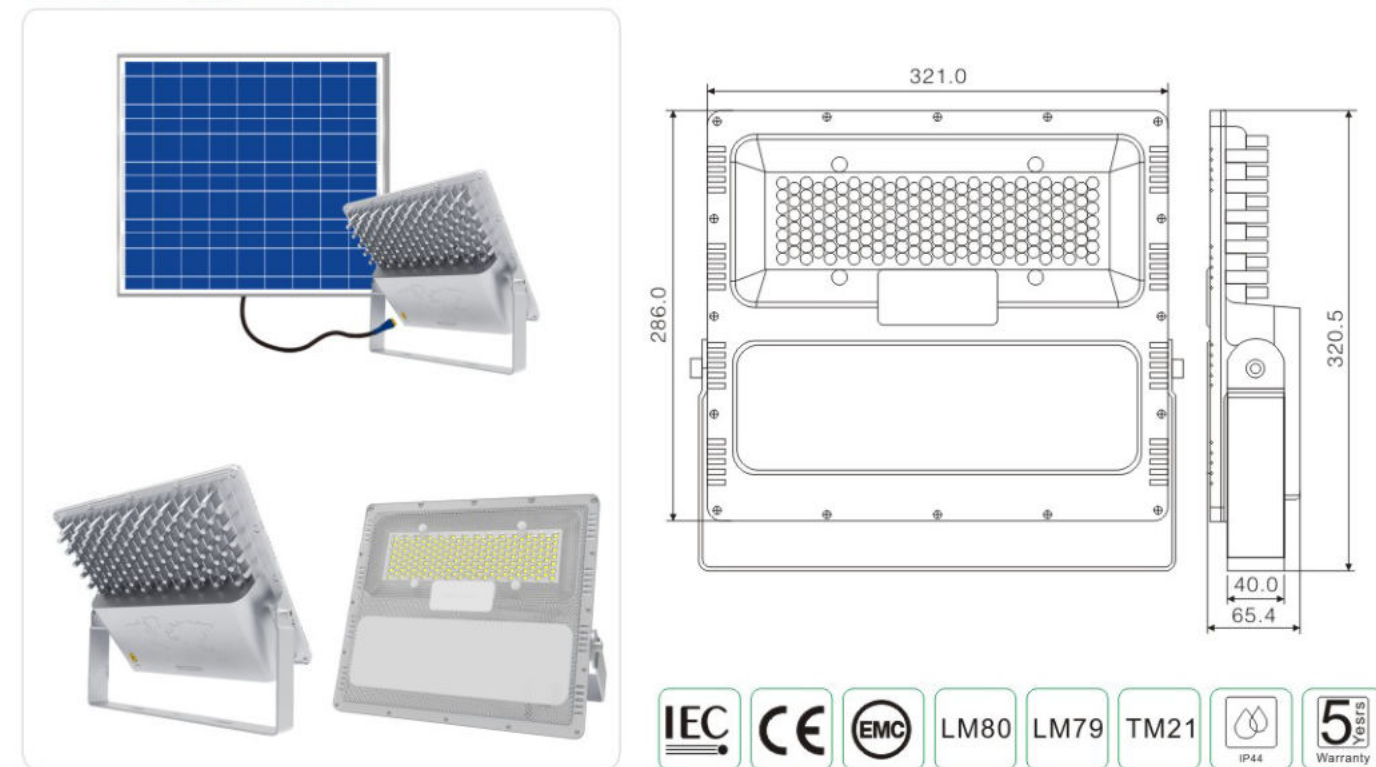

Code	SWSF02
Power	80W
Light Size	321*286*65mm
Net weight	9.8kg
Lumens	6300lm
Efficacy	80lm/w
Material	Die Casting Aluminum
CRI	>70
CCT	2700-6500K
Beam Angle	120°
Solar Panel info	Panel Power:65W, Size:670*603mm Lifetime:25 years
Battery	3.2V/50000mAH 95%DOD LiFePo4Battery Life span:8-12years
Lighting Mode	Full power lighting for the first 4 hours, intelligent power control after 4 hours
Control Mode	remote control
Application	streets , roads, parks, squares , gardens and other public places

• Solar Flood Light: SWHT SF01



Code	SWHTSF01			
Power	5W	8W	12W	15W
Light Size	208*160*56mm	250*202*69mm	274*225*80mm	321*263*90mm
Net weight	2.1kg	2.7kg	3.6kg	4.7kg
Lumens	400lm	640lm	960lm	1200lm
Efficacy	80lm/w	80lm/w	80lm/w	80lm/w
Material	Unti UV ABS Plastic + Tempered glass			
LED chip	Epistar SMD2835			
CRI	>70			
CCT	2700-6500K			
Beam Angle	120°			
Solar Panel type	polycrystalline silicon solar panel			
Solar Panel info	6V8W 235*350*17mm	6V10W 235*350*17mm	6V12W 290*350*17mm	6V15W 350*350*17mm
Battery	lithium iron phosphate battery 6000mah/6V	lithium iron phosphate battery 8000mah/6V	lithium iron phosphate battery 10000mah/3.2V	lithium iron phosphate battery 15000mah/3.2V
Charging time	8 Hours			
Lighting time	24-36 Hours			
Control Mode	Light-dependent control /Time program control/Remote control			
Install suggestion	Fix on wall			
Accessories	5M waterproof cable/ U size holder/Remote controller			

• Led Solar Light: SW-SWL

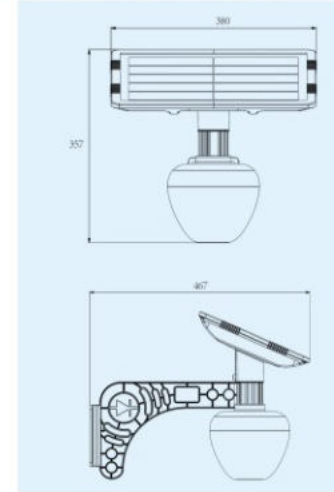

Code	SW-SWL10W	SW-SWL12W	SW-SWL18W
Input voltage	3.2V	3.2V	3.2V
Power	10w	12w	18w
Light Size	467*380*357mm	426*468*442mm	583*438*360mm
Net weight	6.3kg	7.8kg	10kg
Lumens	810lm	880lm	1500lm
Efficacy	80lm/w	75lm/w	80lm/w
Material	Die Casting Aluminum		
Led chip	Cree SMD2835		
CCT	>80		
Beam Angle	120°		
Solar Panel info	5V 18W Solar panel SIZE: 380*254*30mm	5V 30W Solar panel SIZE: 468*362*30mm	5V 36W Solar panel SIZE: 583*360*30mm
Battery	3.2V/13AH Lithium Iron Phosphate Battery- LiFePO ₄	3.2V/26AH Lithium Iron Phosphate Battery- LiFePO ₄	3.2V/26AH Lithium Iron Phosphate Battery- LiFePO ₄
Surge Protection	4KV		
Lighting Mode	All night lighting, the first 4 hrs full power lighting, the rest night lighting is intelligent power control.		
Control Mode	Light sensor, intelligent control		
Install suggestion	2.5-3.5m Height 10-15m Distance	2.5-3.5m Height 10-15m Distance	3-5m Height 15-20m Distance
Operating temperature	-47-70°C		

• LED Corn Bulb:SWYM01



Code	SWYM01		
Input voltage	AC86-265V		
Power	30W	50W	70W
Size	φ 87*235 mm	φ 94*280 mm	φ 121*306 mm
Lumens	3300lm	5500lm	7700lm
Efficacy	110lm/w	110lm/w	110lm/w
Material	thermal conductive plastics+die-casting Aluminium		
LED chip brand	Bridgelux SMD2835		
Driver type	Non-isolated		
CRI	>80 or >70		
CCT	2700-6500K		
Beam Angle	360°		
Power Factor	>0.95		
Surge Protection	2KV		

• LED Corn Bulb High:SWYM05



Code	SWYM05				
Input voltage	AC86-265V				
Power	20W	30W	40W	60W	80W
Size	93*185mm	93*221mm	93*253mm	93*277mm	125*259mm
Lumens	2600lm	3900lm	5200lm	7800lm	10400lm
Efficacy	130lm/w	130lm/w	130lm/w	130lm/w	130lm/w
Material	Aluminum +PC cover				
LED chip brand	Bridgelux SMD2835				
Driver type	Isolated				
CRI	>80 or >70				
CCT	2700-6500K				
Beam Angle	360°				
Power Factor	>0.95				
Light Base	E40/E39/E27/E26				
Surge Protection	2KV				

• LED Corn Bulb:SWYM05

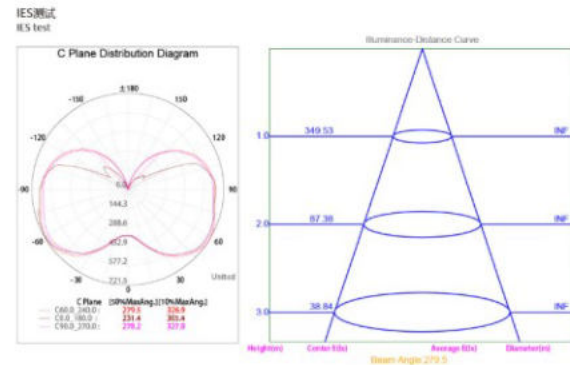
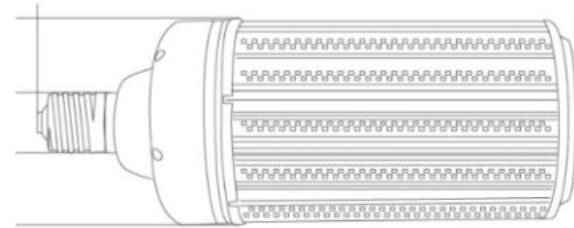

Code	SWYM05			
Input voltage	AC86-265V			
Power	100W	120W	150W	200W
Size	125*278mm	125*294mm	125*324mm	125*330mm
Lumens	13000lm	15600lm	19500lm	26000lm
Efficacy	130lm/w	130lm/w	130lm/w	130lm/w
Material	Aluminum +PC cover			
LED chip brand	Bridgelux SMD2835			
Driver type	Isolated			
CRI	>80 or >70			
CCT	2700-6500K			
Beam Angle	360°			
Power Factor	>0.95			
Light Base	E40/E39			
Impact of Resistance	IK07			
Surge Protection	2KV			

• LED Street Light: SW034

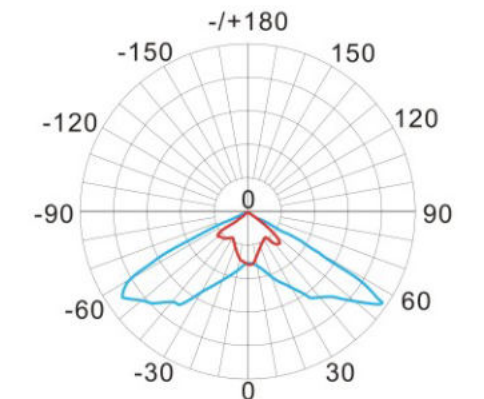
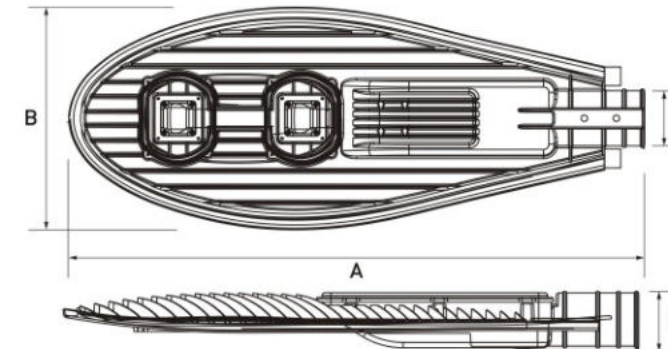

average beam angle(50%): 123.8°/112.2°



Code	SW034				
Input voltage	AC86-265V				
Power	50w	100W	150W	200W	250W
Size	495*245*65mm	700*275*75mm	850*325*75mm	920*325*75mm	1010*360*95mm
Net weight	2kg	4.2kg	5.8kg	8.2kg	11.5kg
Lumens	4500lm	9000lm	13500lm	18000lm	22500lm
Efficacy	90lm/w	90lm/w	90lm/w	90lm/w	90lm/w
Material	Die Casting Aluminum				
LED chip brand	Epistar/Bridgelux COB				
Driver brand	Done/Sosen				
CRI	>70				
CCT	2700-6500K				
Beam Angle	120*60°				
Power Factor	>0.9				
Surge Protection	4KV				
Holder size	φ60mm				
Options	Photocell sensor ,Smart control device, Dimmable Program				

LED Street Light: SW-ZG-ZHX

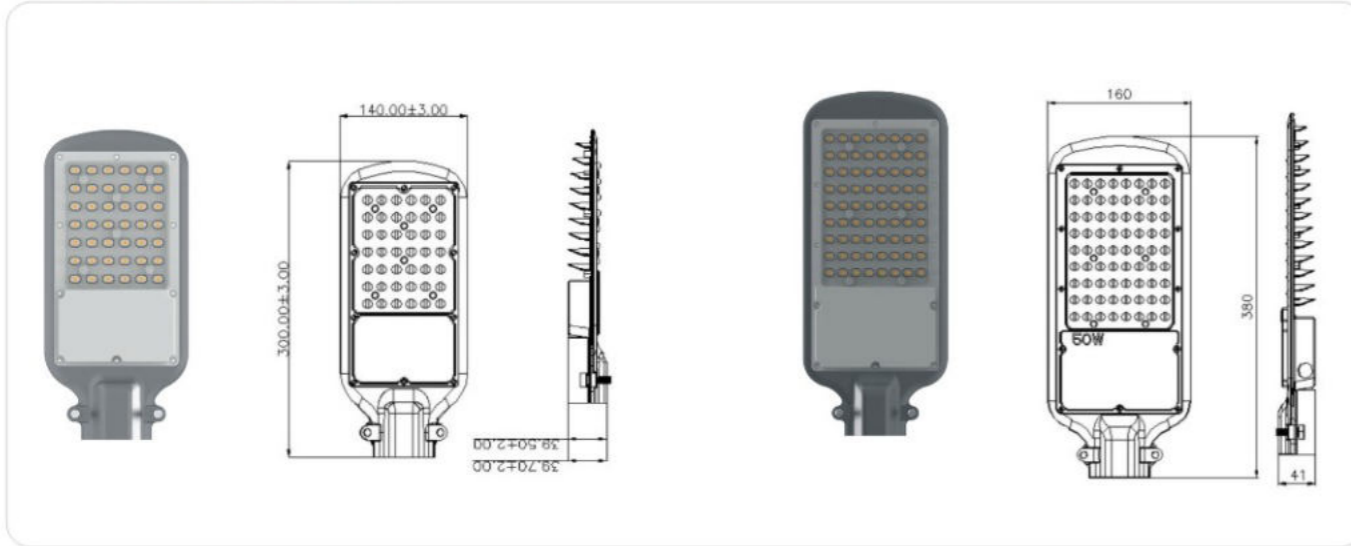

Code	SW-ZG-ZHX							
Input voltage	AC86-265V							
Power	30W	50W	80W	100W	120W	150W	200W	250W
Size	300*140*39.5mm	380*160*41mm	480*230*47mm	480*230*47mm	480*230*47mm	543*291*90mm	543*291*90mm	543*291*90mm
Net weight	1.4kg	2kg	3.5kg	3.5kg	3.5kg	4.8kg	4.8kg	4.8kg
Lumens	3000lm	5000lm	8000lm	10000lm	12000lm	15000lm	20000lm	25000lm
Efficacy	120lm/w	120lm/w	120lm/w	120lm/w	120lm/w	120lm/w	120lm/w	120lm/w
Material	Die Casting Aluminum							
LED chip brand	Epistar/Bridgelux SMD3030							
Driver brand	Done/Sosen							
CRI	>80 or >70							
CCT	2700-6500K							
Beam Angle	140°70°							
Power Factor	>0.9							
Surge Protection	4KV							
Holder size	φ60mm							
Options	Photocell sensor ,Smart control device, Dimmable Program							

LED Street Light: SW-FD50

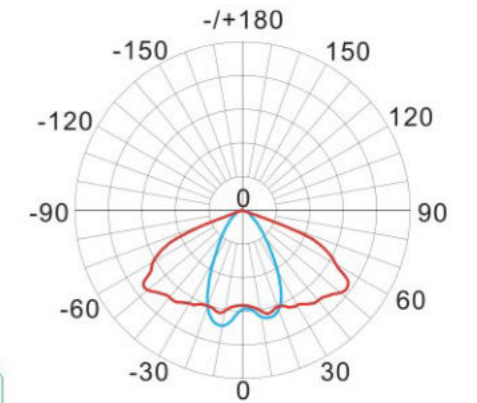
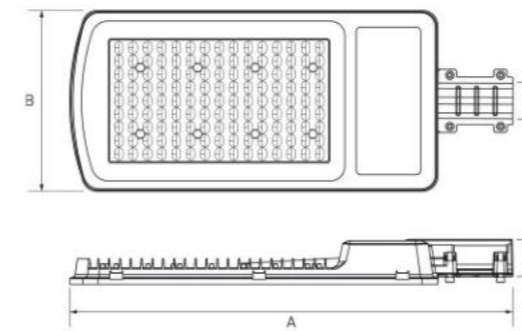

average beam angle: 180°/270°

Code	SW-FD50			
Input voltage	AC86-265V			
Power	50w	100W	120W	200W
Size	410*160*36mm	460*190*40mm	520*210*42mm	630*230*45mm
Net weight	1.4kg	1.9kg	2.7kg	3.9kg
Lumens	5000lm	10000lm	12000lm	20000lm
Efficacy	100lm/w	100lm/w	100lm/w	100lm/w
Material	Die Casting Aluminum			
LED chip brand	Epistar/Bridgelux SMD3030			
Driver brand	Done/Sosen			
CRI	>70			
CCT	2700-6500K			
Beam Angle	120°60°			
Power Factor	>0.9			
Surge Protection	4KV			
Holder size	φ60mm			
Options	Photocell sensor ,Smart control device, Dimmable Program			

· LED Street Light :SW-FD80

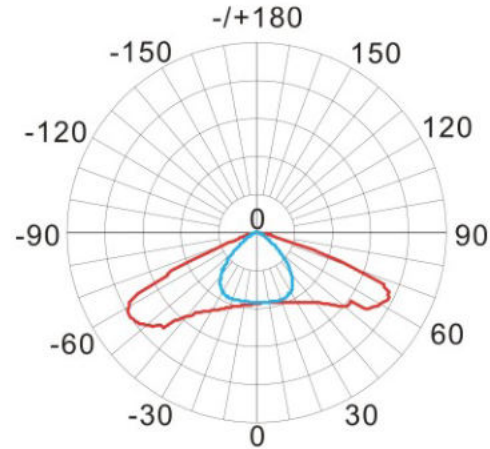
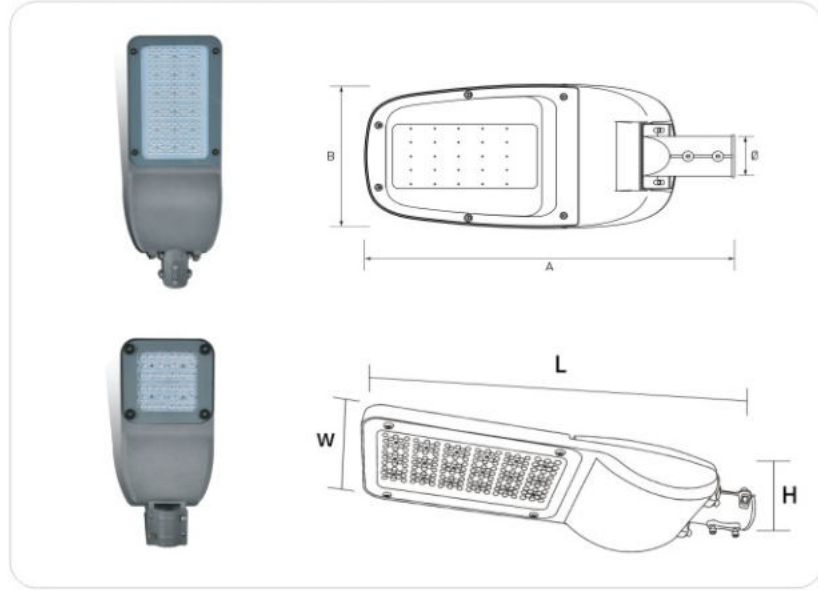

average beam angle: 130° x 60°



Code	SW-FD80				
Input voltage	AC86-265V				
Power	40W	60W	100W	150W	200W
Size	330*150*65mm	375*150*65mm	525*180*75mm	650*260*95mm	700*260*95mm
Net weight	1.8kg	2.2kg	3.5kg	4.5kg	6kg
Lumens	4800lm	7200lm	12000lm	18000lm	24000lm
Efficacy	120lm/w	120lm/w	120lm/w	120lm/w	120lm/w
Material	Die Casting Aluminum				
LED chip brand	Epistar/Bridgelux SMD3030				
Driver brand	Done/Sosen				
CRI	>70				
CCT	2700-6500K				
Beam Angle	140*70°				
Power Factor	>0.9				
Surge Protection	4KV				
Holder size	φ60mm				
Options	Photocell sensor ,Smart control device, Dimmable Program				

· LED Street Light: SW-ST090

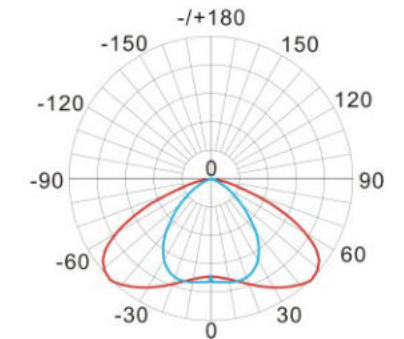
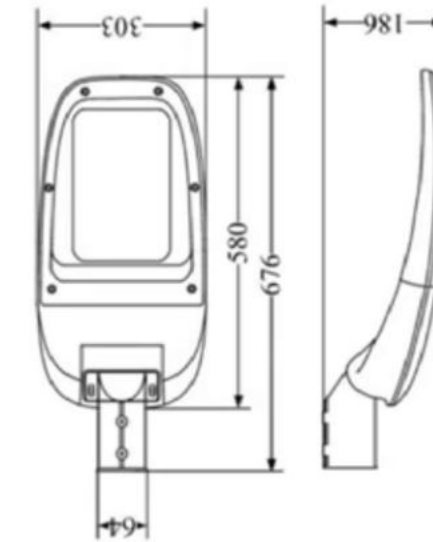

average beam angle: (50%Imax) 134.21x111.9



Code	SW-ST090			
Input voltage	AC86-265V			
Power	50W	100W	150W	200W
Size	510*210*140mm	640*260*165mm	640*260*165mm	850*366*198mm
Net weight	3.2kg	4.9kg	6.4kg	12kg
Lumens	6500lm	13000lm	19500lm	26000lm
Efficacy	130lm/w	130lm/w	130lm/w	130lm/w
Material	Die Casting Aluminum			
LED chip brand	Epistar/Bridgelux SMD3030			
Driver brand	Done/Sosen			
CRI	>80 or >70			
CCT	2700-6500K			
Beam Angle	140*70°			
Power Factor	>0.9			
Surge Protection	10KV			
Holder size	φ60mm			
Options	Photocell sensor ,Smart control device, Dimmable Program			

· LED Street Light: SW-ST11



Code	SW-ST11					
Input voltage	AC86-265V					
Power	50w	100W	150W	200W	250W	300W
Size	450*280*100mm	550*280*100mm	650*280*100mm	750*280*100mm	850*280*100mm	950*280*100mm
Net weight	2.8kg	3.6kg	4.4kg	5.2kg	6kg	6.8kg
Lumens	6000lm	12000lm	18000lm	24000lm	30000lm	36000lm
Efficacy	120lm/w	120lm/w	120lm/w	120lm/w	120lm/w	120lm/w
Material	Die Casting Aluminum					
LED chip brand	Epistar/Bridgelux SMD3030					
Driver brand	Done/Sosen					
CRI	>70					
CCT	2700-6500K					
Beam Angle	140°/70° /60° /90° /120°					
Power Factor	>0.9					
Surge Protection	10KV					
Holder size	φ60mm					
Options	Photocell sensor ,Smart control device, Dimmable Program					

· LED street light: SW-ST12



Code	SW-ST12					
Input voltage	AC86-265V					
Power	50w	100W	150W	200W	250W	300W
Size	550*280*100mm	650*280*100mm	750*280*100mm	850*280*100mm	950*280*100mm	1050*280*100mm
Net weight	2.2kg	3kg	3.7kg	4.5kg	5.2kg	5.9kg
Lumens	6000lm	12000lm	18000lm	24000lm	30000lm	36000lm
Efficacy	120lm/w	120lm/w	120lm/w	120lm/w	120lm/w	120lm/w
Material	Die Casting Aluminum					
LED chip brand	Epistar/Bridgelux SMD3030					
Driver brand	Done/Sosen					
CRI	>80					
CCT	2700-6500K					
Beam Angle	140°/70° /60° /90° /120°					
Power Factor	>0.9					
Surge Protection	10KV					
Holder size	φ60mm					
Options	Photocell sensor ,Smart control device, Dimmable Program					

· Modular LED flood light: SWTGDF02

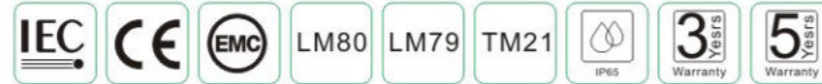
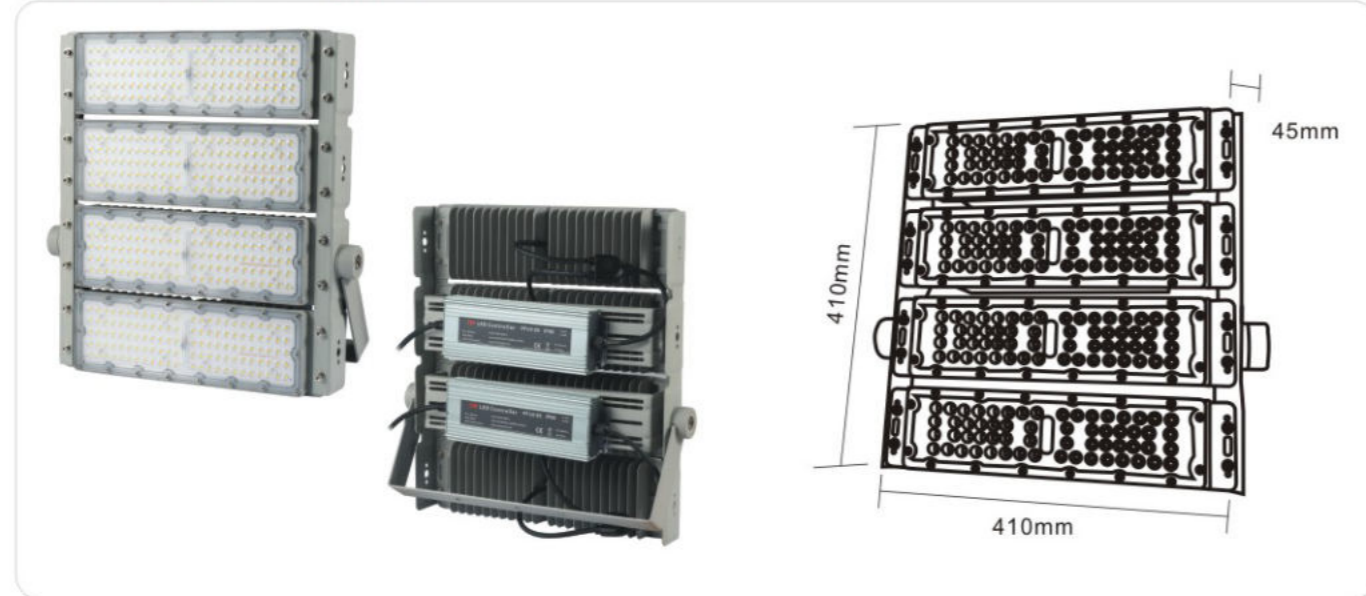

Code	SWTGDF02				
Input voltage	AC100-265V				
Power	100W	200W	300W	400W	500W
Size	350*152*40mm	350*315*40mm	660*232*40mm	660*315*40mm	660*395*40mm
Net weight	2.8kg	4.9kg	7.5kg	9.5kg	11.3kg
Lumens	10000lm	20000lm	30000lm	40000lm	50000lm
Efficacy	100-110lm/w	100-110lm/w	100-110lm/w	100-110lm/w	100-110lm/w
Material	Die Casting Aluminum				
LED chip brand	Epistar/ Philips SMD3030				
Driver brand	Isolated				
CRI	>80 or >70				
CCT	2700-6500K				
Beam Angle	60° /90°				
Power Factor	>0.9				
Withstand Voltage	3KV				
Surge Protection	6KV				

· LED Flood Light: SWTGDF04

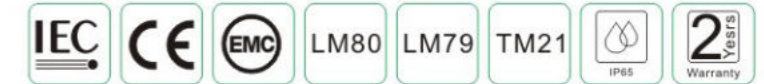
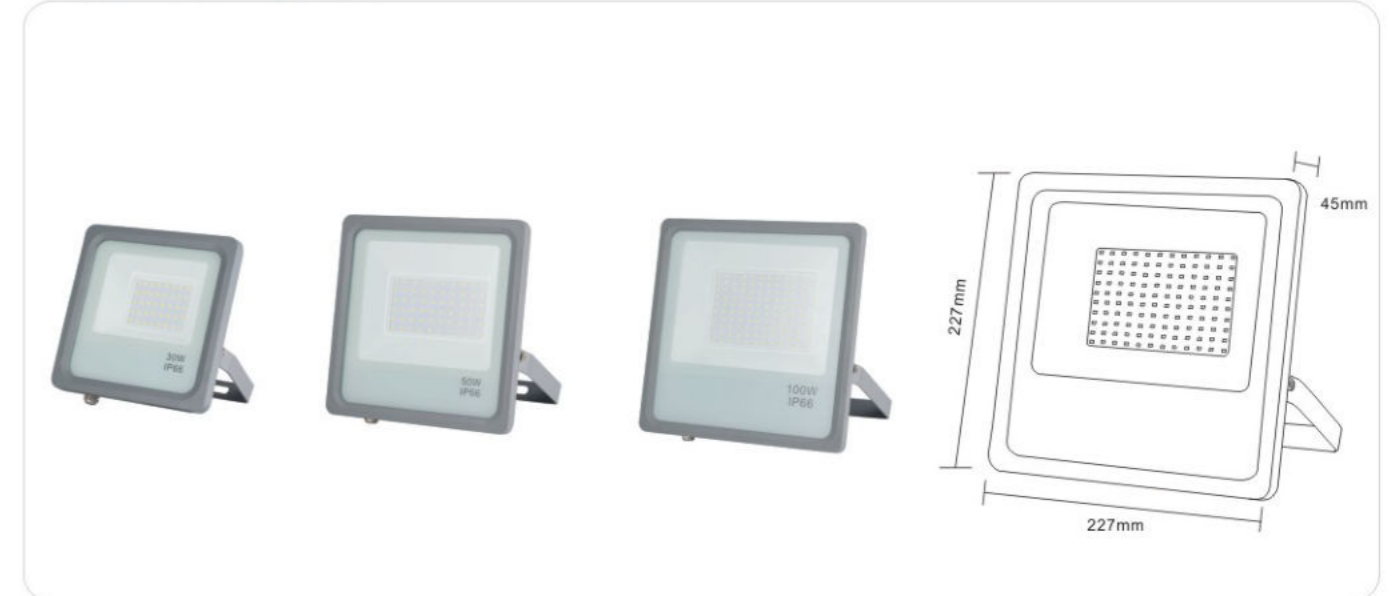

Code	SWTGDF04				
Input voltage	AC100-265V				
Power	30W	50W	100W	150W	200W
Size	170*150*35mm	240*210*44mm	270*260*45mm	310*280*55mm	345*330*55mm
Net weight	0.54kg	1.16kg	1.57kg	2.25kg	3.03kg
Lumens	2700lm	4500lm	9000lm	13500lm	18000lm
Efficacy	90lm/w	90lm/w	90lm/w	90lm/w	90lm/w
Material	Die Casting Aluminum				
LED chip brand	Epistar/ San' an SMD3030				
Driver brand	Isolated				
CRI	>80 or >70				
CCT	2700-6500K				
Beam Angle	120°				
Power Factor	>0.9				
Withstand Voltage	3KV				
Surge Protection	4KV				

· LED Flood Light : SWTGDF03



Code		SWTGDF03				
Input voltage	AC100-265V					
Power	50W	70W	100W	150W	200W	
Size	192*145*30mm	237*175*30mm	273*200*30mm	313*234*35mm	355*263*35mm	
Net weight	0.52kg	0.83kg	1.09kg	1.52kg	2.06kg	
Lumens	4500lm	6300lm	9000lm	13500lm	18000lm	
Efficacy	90lm/w	90lm/w	90lm/w	90lm/w	90lm/w	
Material	Die Casting Aluminum					
LED chip brand	Epistar/ San* an SMD3030					
Driver brand	DOB type					
CRI	>80 or >70					
CCT	2700-6500K					
Beam Angle	120°					
Power Factor	>0.9					
Withstand Voltage	1.5KV					
Surge Protection	2KV					

· LED Flood Light: SWTGDH01

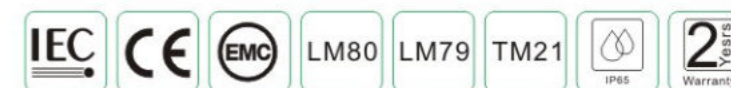

Code		SWTGDH01				
Input voltage	AC85-265V					
Power	50W	100W	200W	400W	600W	
Size	240*270*65mm	280*315*105mm	340*375*105mm	310*280*55mm	775*445*120mm	
Net weight	1.8kg	3.5kg	1.57kg	5.5kg	16.9kg	
Lumens	5000lm	10000lm	20000lm	40000lm	60000lm	
Efficacy	100lm/w	100lm/w	100lm/w	100lm/w	100lm/w	
Material	Die Casting Aluminum					
LED chip brand	Epistar COB					
Driver brand	isolated					
CRI	>80 or >70					
CCT	2700-6500K					
Beam Angle	120°					
Power Factor	>0.9					
Withstand Voltage	1.5KV					
Surge Protection	2KV					

· LED Flood Light: SWTGDH02



Code	SWTGDH02			
Input voltage	AC160-300V			
Power	50W	100W	150W	200W
Size	269*176*34mm	306*225*40mm	414*296*41mm	448*327*41mm
Net weight	0.6kg	0.9kg	1.5kg	1.7kg
Lumens	4000lm	8000lm	12000lm	16000lm
Efficacy	80lm/w	80lm/w	80lm/w	80lm/w
Material	Die Casting Aluminum			
LED chip brand	San' an SMD3030			
Driver brand	Non-isolated			
CRI	>70			
CCT	2700-6500K			
Beam Angle	120°			
Power Factor	>0.9			
Withstand Voltage	1.5KV			
Surge Protection	4KV			

· LED Flood Light: SWTGDF01



Code	SWTGDF01				
Input voltage	AC100-265V				
Power	30W	50W	100W	150W	200W
Size	170*150*35mm	240*210*44mm	270*260*45mm	310*280*55mm	345*330*55mm
Net weight	0.54kg	1.16kg	1.57kg	2.25kg	3.03kg
Lumens	4800lm	7200lm	12000lm	18000lm	24000lm
Efficacy	90lm/w	90lm/w	90lm/w	90lm/w	90lm/w
Material	Die Casting Aluminum				
LED chip brand	Epistar/ San' an SMD3030				
Driver brand	Isolated				
CRI	>80 or >70				
CCT	2700-6500K				
Beam Angle	120°				
Power Factor	>0.9				
Withstand Voltage	1.5KV				
Surge Protection	2KV				